



actalliance

THE LUTHERAN WORLD FEDERATION

Somalia Area Program

Lutheran World Federation is seeking bids for the:

**CONSTRUCTION OF DISSABILITY-FRIENDLY SEMI-
PERMANENT LATRINES AND WASH STATIONS IN
DHOBLEY , SOMALIA.**

SOMALIA:

**NOVEMBER 6th
2023**

A. INVITATION TO TENDER

Lutheran World Federation (LWF) invites tenders from approved and reputable building works Contractors for the above work.

A. INSTRUCTIONS TO TENDERERS.

1. General

1.1 Tenderers shall include the following information and documents with their Tenders, unless otherwise stated:

- (a) Copies of Valid certificates of registration/incorporation from Public works and Housing
- (b) Valid Certificate of registration from Dhobley District Administration
- (c) Valid Certificate from Ministry of Trade and Commerce
- (d) Tax compliance Certificate
- (e) Security Clearance – JISA
- (f) Dully filled, signed and stamped business questionnaire
- (g) Dully filled, signed and stamped Form of Tender

1.2 The Tenderer shall bear all costs associated with the preparation and submission of his/hertender and LWF will in no case be responsible or liable for those costs.

1.3 The Tenderer, at the Tenderer's own responsibility and risk, is encouraged to visit and examine the site of the works and its surroundings, and obtain all information that may be necessary for preparing the tender and entering into a contract for construction of the Works. The costs of visiting the Site shall be at the Tenderer's own expense.

1.4 The procurement entity's employees, committee members, board members and their relative (spouse and children) are not eligible to participate in the tender.

2. Tender Documents

2.1 The complete set of tender documents comprises the documents listed here below: -

- (a) These instructions to Tenderers
- (b) Form of Tender
- (c) Bills of Quantities/Schedule of Rates (whichever is applicable)
- (d) Other materials required to be filled and submitted in accordance with these Instructions and Conditions

- 2.2 The Tenderer shall examine all instructions, forms and specifications in the tender documents. Failure to furnish all information required by the tender documents may result in rejection of his/her tender.
- 2.3 Prospective Tenderers making inquiries of the tendering documents may notify LWF in writing via email (procurement.kismayo@lutheranworld.org) at least a week before the closure of the tender. The LWF will respond to any request for clarification received earlier than five [5] days prior to the deadline for submission of tenders. Copies of LWF's response will be forwarded to all persons issued with tendering documents, including a description of the inquiry, but without identifying its source.
- 2.4 Before the deadline for submission of tenders, LWF may modify the tendering documents by issuing addenda. Any addendum thus issued shall be part of the tendering documents and shall be communicated in writing to all Tenderers. Prospective Tenderers shall acknowledge receipt of each addendum in writing to LWF.

3. Preparation of Tenders

- 3.1 All documents relating to the tender and any correspondence shall be in English language.
- 3.2 The tender submitted by the Tenderer shall comprise the following: -
 - (a) The Tender;
 - (b) Priced Bill of Quantities/Schedule of Rates for lump-sum Contracts
 - (c) Any other materials required to be completed and submitted by Tenderers.
- 3.3 The Tenderer shall fill in rates and prices for all items of the Works described in the Bill of Quantities/Schedule of Rates. Items for which no rate or price is entered by the Tenderer will not be paid for when executed and shall be deemed covered by the other rates and prices in the Bill of Quantities/Schedule of Rates.
- 3.4 The rates and prices quoted by the Tenderer shall not be subject to any adjustment during the performance of the Contract.
- 3.5 The unit rates and prices shall be in USD.
- 3.6 The Tenderer shall prepare one original of the documents comprising the tender documents as described in these Instructions to Tenderers.
- 3.7 The original shall be typed or written in indelible ink and shall be signed by a person or persons duly authorized to sign on behalf of the Tenderer. The person or persons signing the tender shall initial all pages of the tender where alterations or additions have been made.
- 3.8 Clarification of tenders shall be requested by the tenderer to be received by the procuring entity not later than 5 days prior to the deadline for submission of tenders.
- 3.9 The procuring entity shall reply to any clarifications sought by the tenderer within 3 days of receiving the request to enable the tenderer to make timely submission of its tender.

4. Submission of Tenders

1. The tender shall be duly filled and dropped at LWF's Dhobley Office situated in Bosnia, Dhobley, Somalia clearly marked **“Construction of Disability-friendly Semi-Permanent Latrines with Wash stations in Dhobley’ Somalia”**
 - 4.1 Tenders shall be delivered to LWF's Dhobley Office address specified above not later than the time and date specified in the invitation to tender
 - 4.2 Any tender received after the deadline for opening tenders will be returned to the tenderer un- opened.

a. Tender Opening and Evaluation

- i. The tenders will be opened immediately after the closure of the bid by the tender opening committee. Tenderers are not expected to attend the opening and evaluation.

- ii. The Tenderers' names, the total amount of each tender and such other details as may be considered appropriate, will be announced at the opening by The Authority. Minutes of the tender opening, including the information disclosed to those present will also be prepared by LWF's procurement officer.
 - iii. Information relating to the examination, clarification, evaluation and comparison of tenders and recommendations for the award of the Contract shall not be disclosed to Tenderers or any other persons not officially concerned with such process until the award to the successful Tenderer has been announced. Any effort by a Tenderer to influence LWF's officials, processing of tenders or award decisions may result in the rejection of his tender.
 - iv. Tenders determined to be substantially responsive will be checked for any arithmetic errors. Errors will be corrected as follows:
 - 1. where there is a discrepancy between the amount in figures and the amount in words, the amount in words will prevail; and
 - 2. where there is a discrepancy between the unit rate and the line item total resulting from multiplying the unit rate by the quantity, the unit rate as quoted will prevail, unless in the opinion of LWF's representative, there is an obvious typographical error, in which case the adjustment will be made to the entry containing that error.
 - 3. In the event of a discrepancy between the tender amount as stated in the Form of Tender and the corrected tender figure in the main summary of the Bill of Quantities/Quotation, the amount as stated in the Form of Tender shall prevail. The Error Correction Factor shall be computed by expressing the difference between the tender amount and the corrected tender sum as a percentage of the Corrected Builder's Work (i.e. corrected tender sum less P.C. and Provisional Sums).
 - (e) The Error Correction Factor shall be applied to all Builders' Work (as a rebate or addition as the case may be) for the purposes of valuations for Interim Certificates and valuation of variations.
 - (f) The amount stated in the tender will be adjusted in accordance with the above procedure for the correction of errors and with concurrence of the Tenderer, shall be considered as binding upon the Tenderer. If the Tenderer does not accept the corrected amount, the tender may be rejected and the Tender Security forfeited.
 - v. The tender evaluation committee shall evaluate the tender within 14 days of the validity period from the date of opening the tender.
- 5.7 Where contract price variation is allowed, the valuation shall not exceed 15% of the original contract price.
- 5.8 Price variation requests shall be processed by the procuring entity within 30 days of receiving the request.
- 5.9 Preference where allowed in the evaluation of tenders shall not exceed 15%
- 5.10 To assist in the examination, evaluation, and comparison of tenders, LWF at its discretion, may request [in writing] any Tenderer for clarification of the tender, including breakdowns of unit rates. The request for clarification and the response shall be via email but no change in the tender price or substance of the tender shall be sought, offered or permitted.
- 5.7 The Tenderer shall not influence LWF on any matter relating to the tender from the time of the tender opening to the time the Contract is awarded. Any effort by the Tenderer to influence LWF or his employees in his decision on tender evaluation, tender comparison or Contract award may result in the rejection of the tender.

b. Award of Contract

- 6.1 The award of the Contract will be made to the Tenderer who has offered the best evaluated tender price.
- 6.2 Notwithstanding the provisions of clause 6.1 above, LWF reserves the right to accept or reject any tender and to cancel the tendering process and reject all tenders at any time prior to the award of Contract without thereby incurring any liability to the affected Tenderer or Tenderers or any obligation to inform the affected Tenderer or Tenderers of the grounds for the action.
- 6.3 The Tenderer whose tender has been accepted will be contacted via phone and email and enter into written contract.
- 6.4 The procuring entity may at any time terminate procurement proceedings before contract award and shall not be liable to any person for the termination.
- 6.5 The procuring entity shall give prompt notice of the termination to the tenderers and on request give its reasons for termination within 7 days of receiving the request from any tenderer.

7 Corrupt and fraudulent practices

- 7.1 The procuring entity requires that the tenderer observes the highest standard of ethics during the procurement process and execution of the contract. A tenderer shall sign a declaration that he has not and will not be involved in corrupt and fraudulent practices.
- 7.2 The procuring entity will reject a tender if it determines that the tenderer recommended for award has engaged in corrupt and fraudulent practices in competing for the contract in question.
- 7.3 Further a tenderer who is found to have indulged in corrupt and Fraudulent practices, risks being debarred from participating in LWF procurement

B. EVALUATION

i) Evaluation Criteria

The tender document submitted will be evaluated in three (3) stages; - General Mandatory, Technical Capacity and Financial. The evaluation process will be in stages as follows: -

1. General Mandatory–Pass/Fail
2. Technical Capacity Evaluation– Pass mark of 60%
3. Financial – Lowest Cost Evaluated bidder

ii) Mandatory Evaluation

The bids shall undergo a general pre-qualification process in order to determine bid compliance to the following mandatory requirements. Tenderers are required to comply to the following requirements, failure to which the firm shall not proceed with the next stage of evaluation: -

NO.	REQUIREMENTS	Pass	Fail
M1	Valid Certificate of Registration/Incorporation from Public works and Housing		
M2	Valid Certificate of registration from Dhobley District		
M3	Valid Tax Compliance Certificate		
M4	Valid certificate from Ministry of trade and Commerce		
M5	Security Clearance - JISA		
M6	Dully filled, signed and stamped business questionnaire		
M7	Dully filled, signed and stamped Form of Tender		

Failure to submit any of the above-mentioned documentation, will lead to disqualification of the firm at the mandatory stage. The bidders that will meet all the mandatory requirements above will qualify to proceed to technical evaluation stage.

iii) Technical Evaluation

Bidder (s) are required to attain minimum of 60% score in the technical requirements, failure to which the firm shall not proceed to the next stage of financial evaluation stage.

iv) Financial Evaluation

The bids that qualify at the Technical Capacity evaluation stage will be subjected to financial evaluation to determine the winner. The lowest evaluated bidder will be considered for award of tender.

The score for the Financial Evaluation is 40%.

ITEMS REQUIRED	DETAILS OF ATTACHMENT REQUIRED	
A: TECHNICAL EVALUATION		100% = (60%)
1) PAST EXPERIENCE 30%	Signed completion certificates. (LWF will confirm the eligibility of the certificates)	30%
2) PERSONNEL 20%	Name, Title and Qualification of Supervisor with construction certificate	6%
	Name, Title and Qualification of foreman with construction certificate	6%
	Copies of CV, 2 certificates from institution	8%
3) BANK ACCOUNT 15%	5 months Authenticated bank statement	15%
4) PLANT & EQUIPMENT 25%	Name 5 relevant Equipment	5%
	Proof of each (Log book, receipt, or Lease)	20%
5) TIME COMMITMENT	Work plan	10%
		Total: 100%
B: FINANCIAL EVALUATION: Priced BoQ		40%

FORM OF TENDER

TO: _____ [Name of Employer) _____ [Date]
_____ [Name of Contract]

Dear Sir/Madam

- 1. In accordance with the Conditions of Contract and Bills of Quantities for the execution of the above-named Works, we, the undersigned offer to construct, install and complete such Works and remedy any defects therein for the sum of USD.

_____ [Amount in figures]

US Dollars _____ [Amount in words]

- 2. We undertake, if our tender is accepted, to commence the Works as soon as is reasonably possible after the receipt of the Project Manager’s notice to commence, and to complete the whole of the Works comprised in the Contract within the time stated in the Appendix to Conditions of Contract.
- 3. We agree to abide by this tender until _____ [Insert date], and it shall remain binding upon us and may be accepted at any time before that date.
- 4. Unless and until a formal Agreement is prepared and executed this tender together with your written acceptance thereof, shall constitute a binding Contract between us.
- 5. We understand that you are not bound to accept the lowest or any tender you may receive.

Dated this _____ day of _____ 2023

Signature _____ in the capacity of _____

Duly authorized to sign tenders for and on behalf of

_____ [Name of Employer]

of _____ [Address of Employer]

Witness; Name _____

Address _____

Signature _____

Date _____

TENDER QUESTIONNAIRE

Please fill in block letters.

- 1. Full names of tenderer
.....
- 2. Full address of tenderer to which tender correspondence is to be sent (unless an agent has been appointed below)
.....
- 3. Telephone number (s) of tenderer
.....
- 4. Email address of tenderer
.....
- 5. Name of tenderer’s representative to be contacted on matters of the tender during the tender period
.....

Signature of Tenderer



LUTHERAN WORLD FEDERATION
Somalia Sub Program

Bills of Quantities

for the

CONSTRUCTION OF DISABILITY-FRIENDLY
SEMI- PERMANENT LATRINES AND WASH
STATIONS IN DHOBLEY & KISMAYO,
JUBBALAND STATE OF SOMALIA.

LOCATION:
Dhobley, Somalia.



SUBMISSION

N



DEADLINE.:

3RD DECEMBER 2023 1700HRS

BoQ for Construction of Disability-Friendly Semi-Permanent Latrines for IDPs in Dhobley, Somalia (Twin-Latrine)

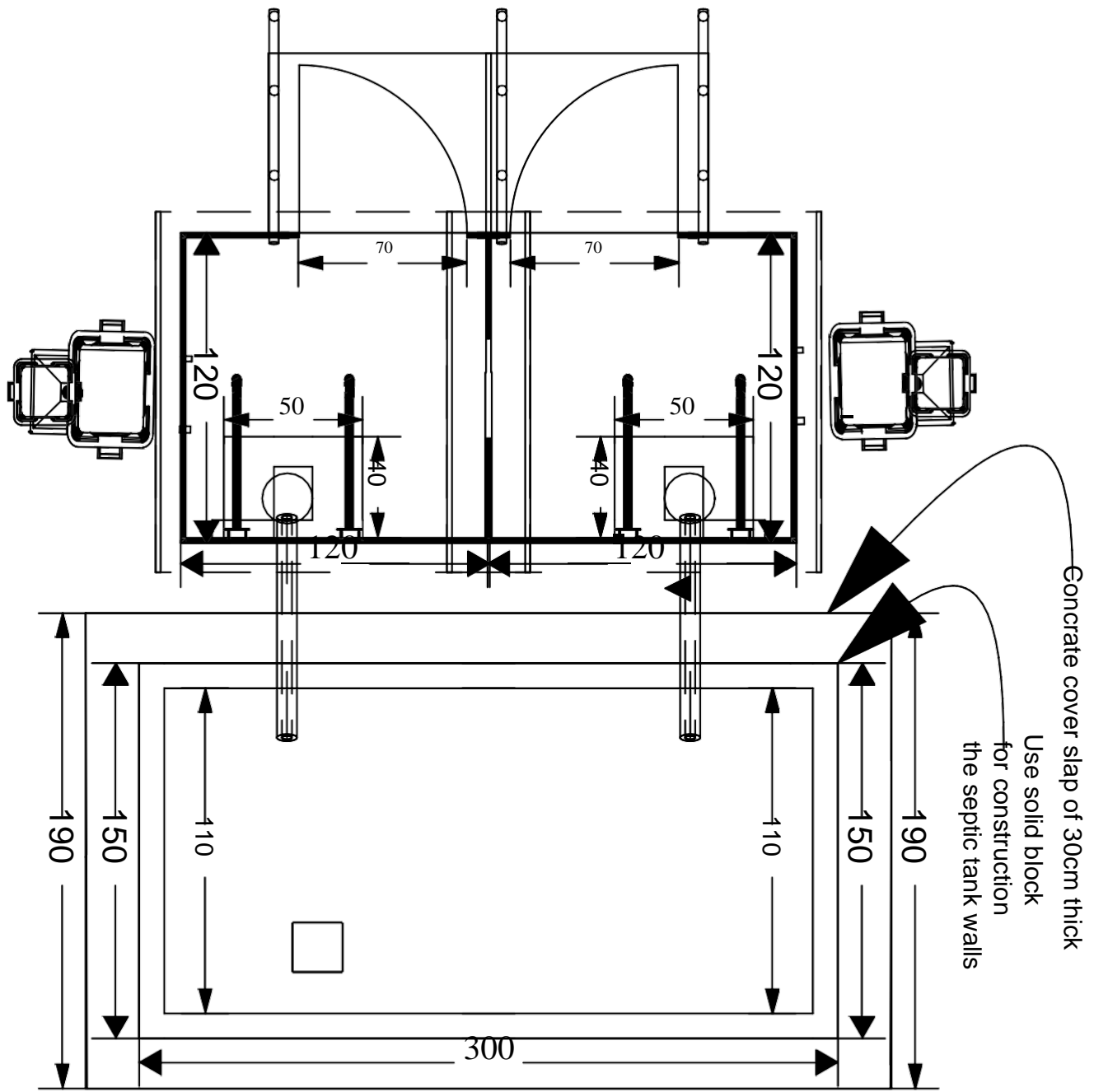

Project: WASH B/NOTE: 1 (6121-09-4870-155-4950-2824)		DF: 5759		
Item Description	Quantity	Unit	Rate (USD)	Total (USD)
Site Preparation				
Site Clearing from unwanted materials(3m x 3m)	9	m ²		
Septic Tank Construction				
Excavation for Septic Tank (3m deep, 3m x 1.5m)	13.5	Cu m		
Solid Block Construction (20cm thick, for the inside walls 9mx3m) using 1:3 ratio	27	m ²		
Reinforced Concrete Cover (30cm thick) use Y12 for the main bars and Y10 for distribution bars double reinforced, 15cm center to center (1.5mx3x0.30)	1.35	Cu m		
Concrete Portable Manhole (30cm x 30cm)	2	L		
Floor Construction				
Concrete Floor (10cm thick, 1:2:3 ratio)	0.45	Cu m		
Super Structure Construction				
CGI guage 28, Anchored with Timber Frame, using Timber Wood of 8cm by 8cm for the vertical Posts, and 4cm by 4cm for the horizontal frame (1.5m x 1.5m)	21	m ²		
Provide and install 2 Stunning CGI doors with a meticulously crafted timber frame, authentic hinges, locks, and other intricate details.	2	Job		
Provide and construct the roof Truss, then apply the iron sheet and roof Accessories (1.5m x3m)	5.175	m ²		
Disability-Friendly Features				
Provide and construct a Concrete Ram with Metal Rails for the twin latrines as shown in the design	2	Job		
Provide and Construct a concrete Bricks for the Toilet (50cm height, with back support)	2	Job		
Provide and fix Metal Hand Support	2	Job		
Sewage Pipe				
Sewage Pipe Installation that has gentle slope	2	Job		
Handwash System				
Handwash System (Jerican, barrel fixed with metal frame and Water Tap) and connect the drainage to the toilet or the septic tank	2	Job		
Branding				
Visible Logo for Donor and LWF and Numbering of the latrines	1	Job		
Grand Total for Construction of twin Disability-Friendly Semi-Permanent Latrine for IDPs	-	-		
Grand Total Construction of 50 twin Disability-Friendly Semi-Permanent Latrines for IDPs	50	-		

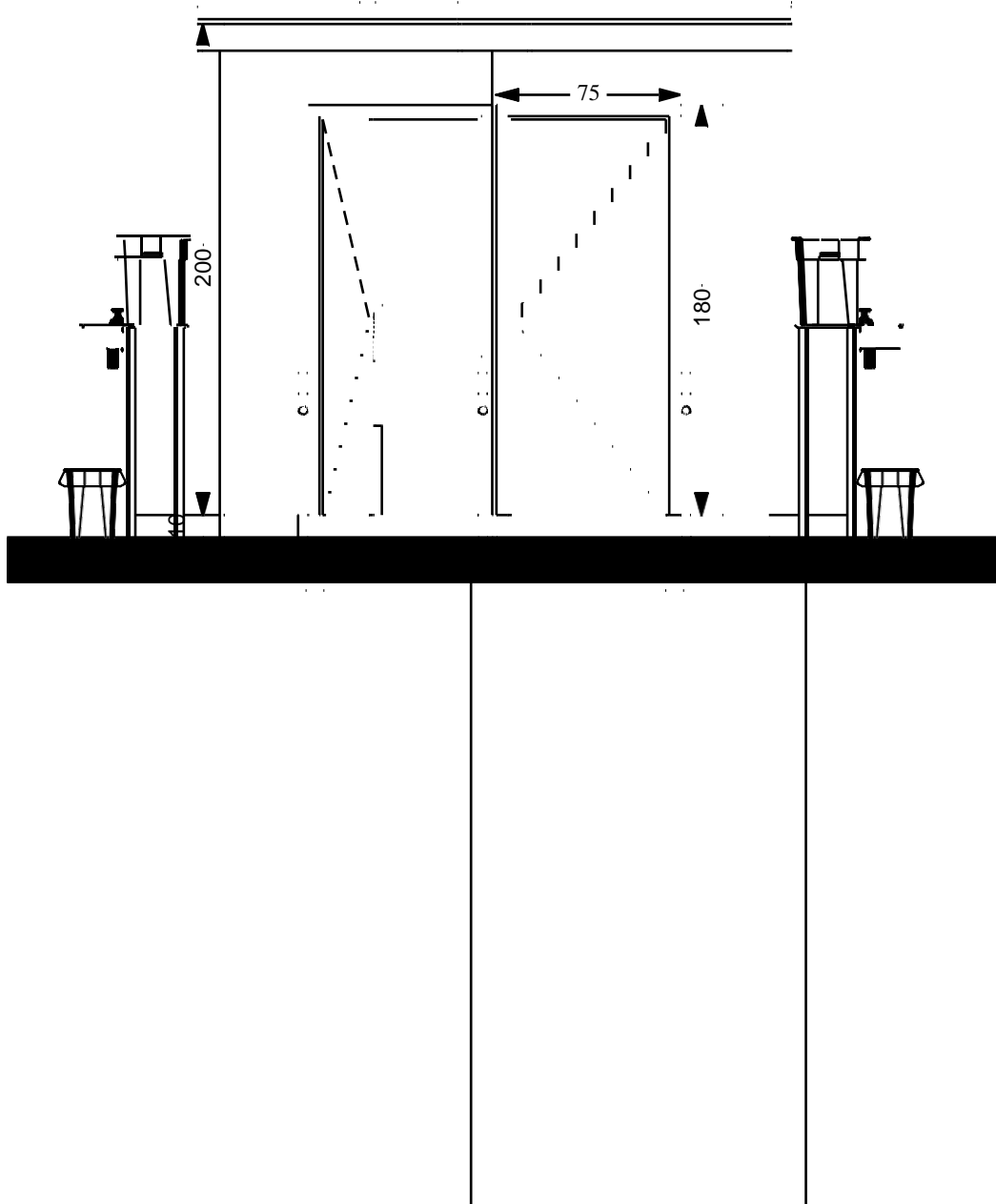

Project title Construction of semi-permanent dissability friendly latrines for IDPs in Dhobley		Date: November to December 2023	
Location: Dhobley, Lower Jubba - Somalia			
Funded by: Canadian Lutheran World Relief (CLWR)	 Canadian Lutheran World Relief	Implemented by: THE LUTHERAN WORLD FEDERATION (LWF)	 THE LUTHERAN WORLD FEDERATION

front elevation



<p>Project title Construction of semi-permanent disability friendly latrines for IDPs in Dhobley, Somalia</p>		<p>Elevation</p>		<p>1:32</p>
<p>Location: Dhobley, Lower Jubba-Somalia</p>		<p>Date: November to December 2023</p>		
<p>Funded by: Canadian Lutheran World Relief (CLWR)</p>	 <p>Canadian Lutheran World Relief</p>	<p>Implemented by: THE LUTHERAN WORLD FEDERATION (LWF)</p>	 <p>THE LUTHERAN WORLD FEDERATION</p>	

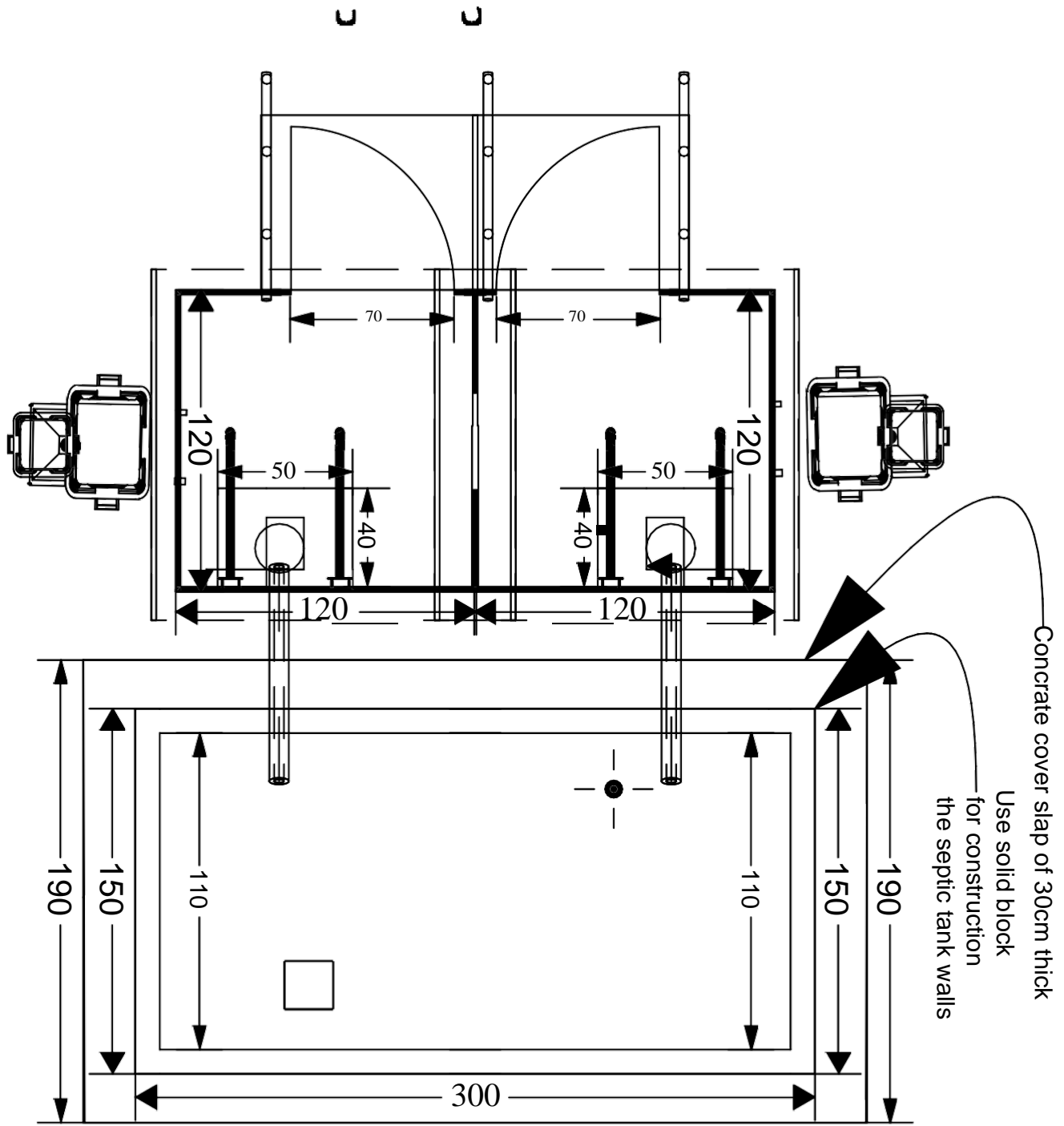

Project title Construction of semi-permanent disability friendly latrines for IDPS in Dhobley	
Location: Dhobley, Lower Jubba - Somalia	Date: November to December 2023
Funded by: Canadian Lutheran World Relief (CLWR)	Implemented by: THE LUTHERAN WORLD FEDERATION (LWF)



SECTION

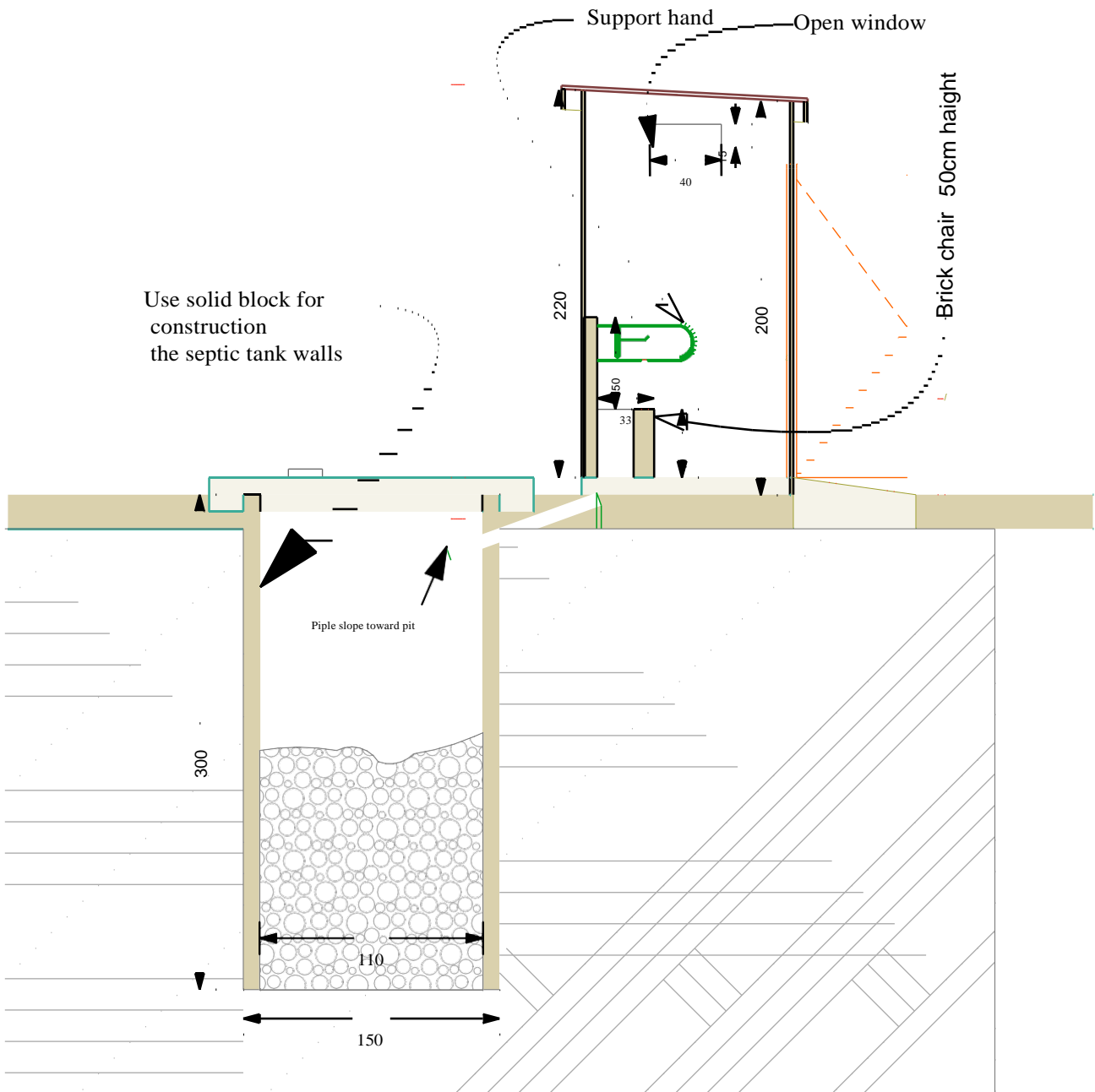

<p>Project title Construction of semi-permanent disability friendly latrines for IDPs in Dhobley</p>		<p>Date: November to December 2023</p>	
<p>Location: Dhobley, Lower Jubba -Somalia</p>		<p>Implemented by: THE LUTHERAN WORLD FEDERATION(LWF)</p>	
<p>Funded by: Canadian Lutheran World Relief (CLWR)</p>		<p>THE LUTHERAN WORLD FEDERATION</p>	



Canadian Lutheran
World Relief



THE
LUTHERAN
WORLD
FEDERATION

side elevation

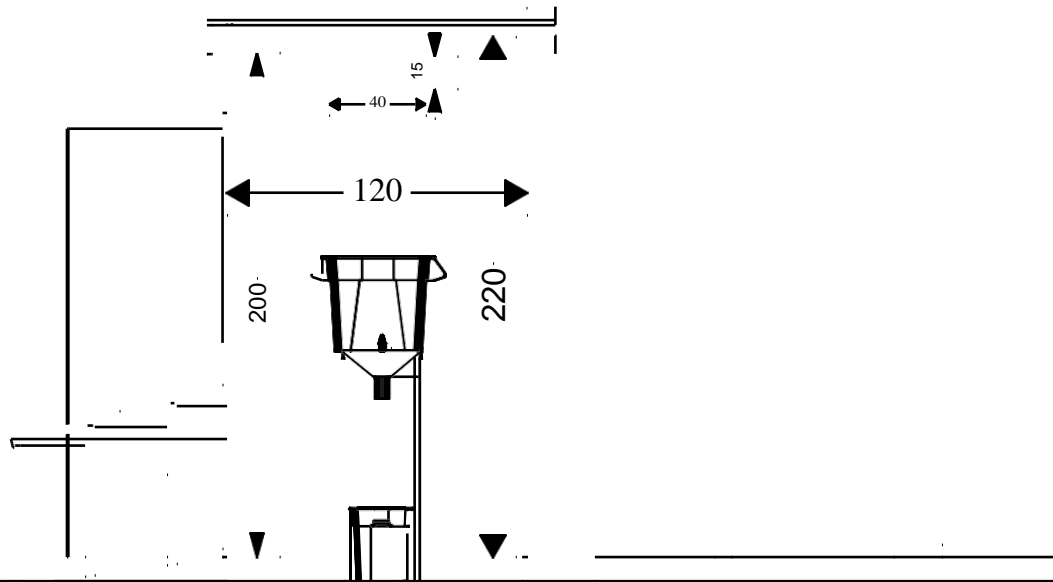

300

man hole

150

Project title
Construction of semi-permanent disability friendly latrines for

Location: IDPs in Dhobley, Dhobley, Lower Jubba-Somalia
Date: November to December 2023

Funded by:
Canadian Lutheran World Relief (CLWR)



Canadian Lutheran World Relief

Implemented by:
THE LUTHERAN WORLD FEDERATION (LWF)



THE LUTHERAN WORLD FEDERATION

Elevation (1)

1:31







